

**ROBE**

# ROBIN<sup>®</sup> CycFX 8

# ROBIN<sup>®</sup> CycFX 8

Wireless DMX  
CRMX<sup>™</sup>

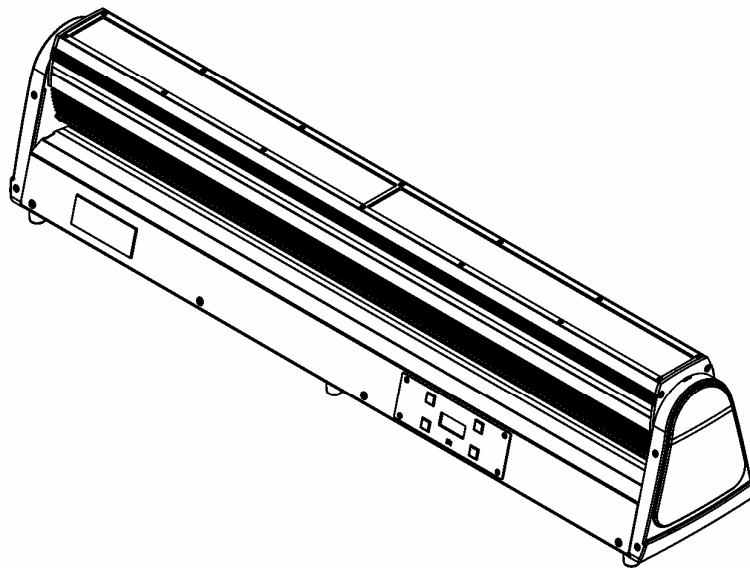

**USER MANUAL**

Version 1.7

ROBE<sup>®</sup> Lighting s.r.o. • Czech republic • [www.robe.cz](http://www.robe.cz)

## Table of contents

1. Safety instructions .....	3
2. Fixture exterior view .....	5
3. Installation .....	5
3.1 Rigging the fixture.....	5
3.2 Connection to the mains .....	6
3.3 DMX 512 connection .....	6
3.4 Wireless DMX operation.....	7
4. Robin CycFX 8- DMX protocol.....	8
5. Control menu map.....	15
6. Control menu.....	18
6.1 Addressing (DMXA).....	18
6.2 Fixture information (Info) .....	18
6.3 Personality (Pers).....	19
6.4 Manual Control (Manual) .....	20
6.5 Test program (Test Prg) .....	20
6.6 Stand-alone (St Alone).....	20
6.7 Reset .....	21
6.8 Special functions (Special) .....	21
7. RDM .....	22
8. Technical specifications .....	23
9. Cleaning and maintenance .....	28
9.1 Replacing a fuse .....	28

**FOR YOUR OWN SAFETY, PLEASE READ THIS USER MANUAL CAREFULLY  
BEFORE POWERING OR INSTALLING YOUR Robin CycFX 8!  
Save it for future reference.**

This device has left our premises in absolutely perfect condition. In order to maintain this condition and to ensure a safe operation, it is absolutely necessary for the user to follow the safety instructions and warning notes written in this manual.

The manufacturer will not accept liability for any resulting damages caused by the non-observance of this manual or any unauthorized modification to the device.

Please consider that damages caused by manual modifications to the device are not subject to warranty.

## 1. Safety instructions

**DANGEROUS VOLTAGE CONSTITUTING A RISK OF ELECTRIC SHOCK IS PRESENT WITHIN THIS UNIT!**

Make sure that the available voltage is not higher than stated on the rear panel of the fixture. This fixture should be operated only from the type of power source indicated on the marking label. If you are not sure of the type of power supplied, consult your authorized distributor or local power company.

Always disconnect the fixture from AC power before cleaning, removing or installing the fuses, or any part.

Do not overload wall outlets and extension cords as this can result in fire or electric shock.

Make sure that the power cord is never crimped or damaged by sharp edges. Check the fixture and the power cord from time to time.

Do not install the unit near naked flames.

During the operation the housing becomes hot.

Refer servicing to qualified service personnel.

**This fixture falls under protection class I. Therefore this fixture has to be connected to a mains socket outlet with a protective earthing connection.**

Do not connect this fixture to a dimmer pack.

**LED light emission. Risk of eye injury.  
Do not look straight at the fixture's LEDs during operation. The intense light beam may damage your eyes.**

Keep combustible materials at least 20 cm away from the fixture.

If the fixture has been exposed to drastic temperature fluctuation (e.g. after transportation), do not switch it on immediately. The arising condensation water might damage your device. Leave the device switched off until it has reached room temperature.

Avoid brute force when installing or operating the fixture.

The fixture was designed for indoor use only.

## Robin CycFX 8

When choosing the installation spot, please make sure that the fixture is not exposed to extreme heat or dust.

Avoid using the unit in locations subject to possible impacts.

The fixture body never must be covered with cloth or other materials.

Only operate the fixture after having checked that the housing is firmly closed and all screws are tightly fastened.

Make sure that the area below the installation place is blocked when rigging, derigging or servicing the fixture.

Do not block the front objective LEDs with any object when the fixture is under operation.

The fixture becomes very hot during operation. Allow the fixture to cool approximately 30 minutes prior to manipulate with it.

Operate the fixture only after having familiarized with its functions. Do not permit operation by persons not qualified for operating the fixture. Most damages are the result of unprofessional operation!

Do not attempt to dismantle or modify the unit.

Please consider that unauthorized modifications on the fixture are forbidden due to safety reasons!

Please use the original packaging if the fixture is to be transported.

If this device will be operated in any way different to the one described in this manual, the product may suffer damages and the guarantee becomes void. Furthermore, any other operation may lead to dangers like short-circuit, burns, electric shock etc.

## 2. Fixture exterior view

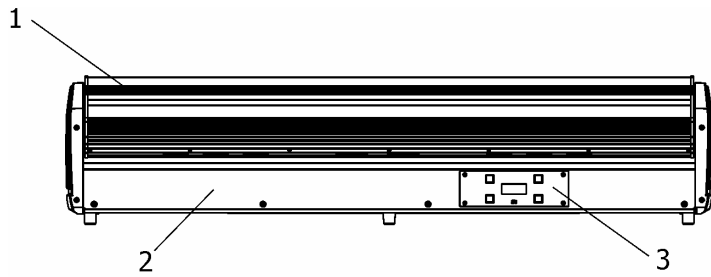

- 1. Moving head
- 2. Base of fixture
- 3. Control panel

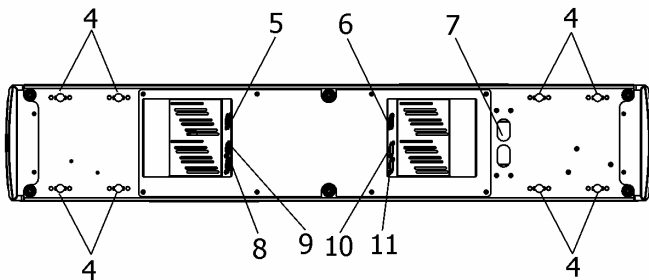

- 4. ¼- turn locks
- 5. Power OUT (Neutrik PowerCon)
- 6. Power IN (Neutrik PowerCon)
- 7. Attachment point for safety wire
- 8. DMX OUT (3-pin XLR)
- 9. DMX OUT (5-pin XLR)
- 10. DMX IN (5-pin XLR)
- 11. DMX IN (3-pin XLR)

## 3. Installation

### 3.1 Rigging the fixture

The Robin CycFX 8 can be rigged in any orientation on a truss without altering its operation characteristics. Installation on a truss allows the mounting adapters (1) fastened to the fixture base with ¼-turn quick locks. Also standard Omega holders for Robe fixtures or mounting bar CF8 (optional accessory) can be used instead mounting adapters. Pull the safety wire through the attachment point (2) and around the truss.

For overhead use, always install a safety wire that can hold at least 10 times the weight of the fixture. You must only use safety wire with screw-on carbine.

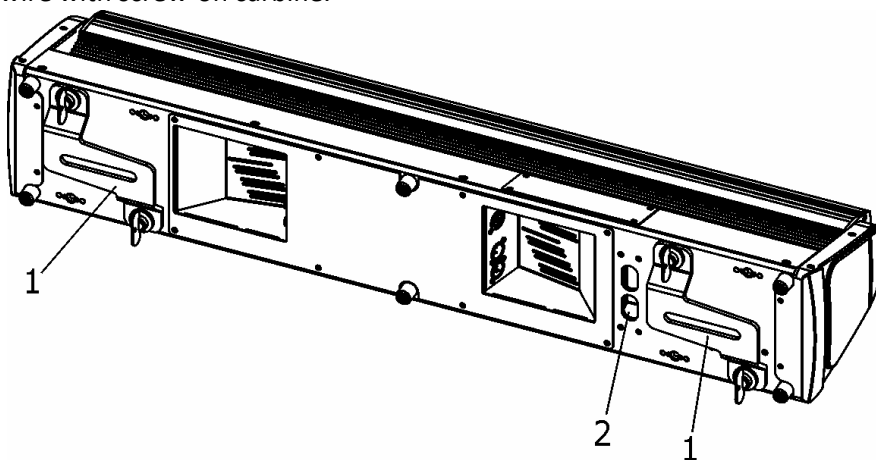

**Ensure that the structure (truss) to which you are attaching the fixture is secure**

**Caution:** Fixtures may cause severe injuries when crashing down! If you have doubts concerning the safety of a possible installation, do not install the device and consult installation with an expert.

Tilt position concerning DMX values is shown on the picture below.

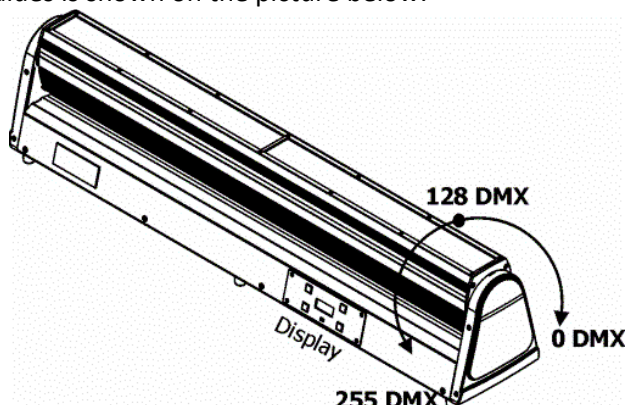

### 3.2 Connection to the mains

**Fixtures must be installed by a qualified electrician in accordance with all national and local electrical and construction codes and regulations.**

Install a suitable plug on the power cord, note that the cores in the power cord are colored according to the following table.

Core (Eu)	Core (US)	Connection	Plug Terminal Marking
Brown	Black	Live	L
Light blue	White	Neutral	N
Yellow/Green	Green	Earth	

**This device falls under class one and must be grounded!**

Design of the Robin CycFX 8 allows to connect several fixtures to AC mains power in one interconnected daisy chain using power input and throughput connectors. Needed daisy chain cords are stated in the chapter “Technical specifications “

The max. number of connected fixtures depends on the AC mains power voltage:

15 fixtures at power supply= 230V

7 fixtures at power supply= 120V

6 fixtures at power supply=100V

Do not overload the supply line and the connecting leads.

### 3.3 DMX 512 connection

The fixture is equipped with 3-pin and 5-pin XLR connectors for DMX input/output. Only use a shielded twisted-pair cable designed for RS-485 and 3-pin/5-pin XLR- connectors in order to connect the controller with the fixture or one fixture with another.

Wiring of the XLR connectors:

DMX input  
XLR socket (rear view):



DMX output  
XLR plug (rear view):



1 – Shield

2 - Signal (-)

3 - Signal (+)

4 – Not connected

5 – Not connected

### To build a DMX chain

1. Connect the DMX output of the controller directly with the DMX input of the first fixture in the DMX chain.
2. Connect the DMX output of the first fixture in the DMX chain with the DMX input of the next fixture.
3. Always connect the DMX output with the input of the next fixture until all fixtures are connected.  
Do not overload the link. Max. 32 fixtures may be connected on a DMX link.

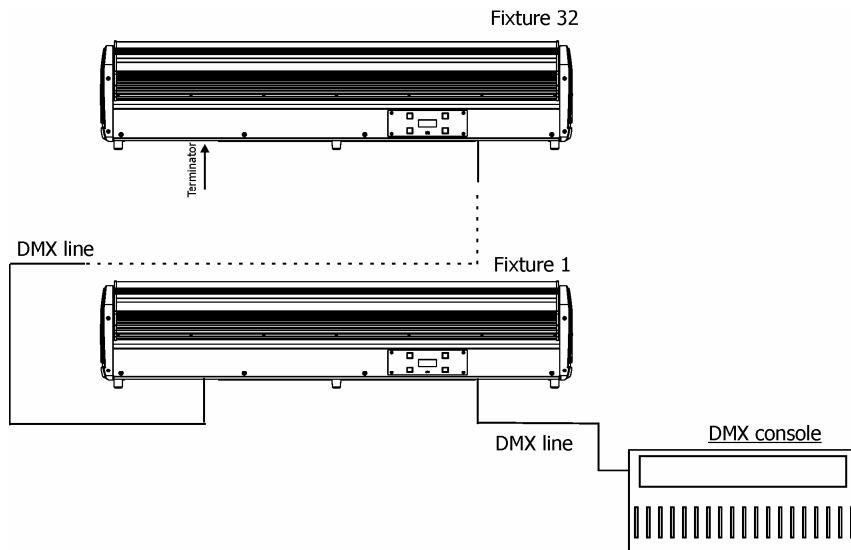

Caution: Terminate the link by installing a termination plug in the output of the last fixture. The termination plug is a male 3-pin XLR plug with a 120 Ohm resistor soldered between Signal (-) and Signal (+).

### 3.4 Wireless DMX operation

The wireless version of the Robin CycFX 8 (Robin CycFX 8/W) is equipped with the Lumen Radio CRMX module and antenna for receiving DMX signal. CRMX module operates on the 2.4 GHz band.

1. Select wireless DMX input from the menu **PErS** (PErS-->dM.IM.-->dM.UL.).
2. To link the fixture with DMX transmitter.  
The fixture can be only linked with the transmitter by running the link procedure at DMX transmitter .  
After linking , the level of DMX signal ( 0-100 %) is displayed in the menu item "r.InF" (SPEC-->rAdI.--> r.InF.)
3. To unlink the fixture from DMX transmitter.  
The fixture can be unlinked from receiver via the menu item " r.UnL." (SPEC-->rAdI.--> r.UnL.).

## 4. Robin CycFX 8- DMX protocol

Version 1.4

Mode/Channel							Value	Function	Type of control							
1	2	3	4	5	6	7										
1	1	1	1	1	1	1	0-255	<b>Tilt (8 bit)</b> Tilt movement by 270°	proportional							
-	2	2	2	-	2	2	0-255	<b>Tilt (16 bit)</b> Fine movement of tilt	proportional							
2	3	3	3	2	3	3	0	Standard mode	Step step							
							1	Max. Speed mode								
							2-255	<b>Tilt speed</b> Speed from max. to min.	proportional							
							2-255	<b>Tilt time</b> Time from 0.2 s to 25.5 s.	proportional							
3	4	4	4	3	4	4	0-9	<b>Special functions</b> Reserved <i>To activate following functions , stop in DMX value for at least 3 sec. and shutter must be closed at least 3 sec. (Shutter channel 13/19 must be at range of 0-31 DMX). Corresponding menu items are temporarily overrided except DMX Input.</i>	step step							
							10-14	DMX input: Wired DMX *								
							15-19	DMX input: Wireless DMX* * function is active only 10 seconds after switching the fixture on								
														20-29	Reserved	step
														30-39	RGBW colour mixing mode	step
														40-49	CMY colour mixing mode	step
														50-59	Tilt speed mode	step
														60-69	Tilt time mode	step
														70-79	Blackout while tilt moving	step
														80-89	Disabled blackout while tilt moving	step
														90-99	Silent zoom On	step
														100-109	Silent zoom Off	step
														110-119	White counting On	step
														120-129	White counting Off	
														130-139	Reserved <i>To activate following reset function, stop in DMX value for at least 3 sec.</i>	
														140-149	Tilt reset	step
														150-179	Reserved	
														180-189	Zoom reset	step
														190-199	Reserved	
							200-209	Total reset	step							
							210-255	Reserved								
4	5	5	5	4	5	5	0-255	<b>Red (Cyan) coarse - all pixels **</b> Red LEDs saturation control (0-100%)	proportional							
-	6	6	6	-	6	6	0-255	<b>Red (Cyan) fine - all pixels **</b> Red LEDs saturation fine control min.—>max.	proportional							
5	7	7	7	5	7	7	0-255	<b>Green (Magenta) coarse - all pixels **</b> Green LEDs saturation control (0-100%)	proportional							

Robin CycFX 8

-	8	8	8	-	8	8	0-255	<b>Green (Magenta) fine - all pixels **</b> Green LEDs saturation fine control min.—>max.	proportional
6	9	9	9	6	9	9	0-255	<b>Blue (Yellow) coarse - all pixels **</b> Blue LEDs saturation control (0-100%)	proportional
-	10	10	10	-	10	10	0-255	<b>Blue (Yellow) fine - all pixels **</b> Blue LEDs saturation fine control min.—>max.	proportional
7	11	11	11	7	11	11	0-255	<b>White coarse (RGBW mode only) - all pixels **</b> White LEDs saturation control (0-100%)	proportional
-	12	12	12	-	12	12	0-255	<b>White fine (RGBW mode only) - all pixels **</b> White LEDs saturation fine control min.—>max.	proportional
8	13	13	13	8	13	13	0 1-255	<b>CTO (All pixels)</b> No function Colour temperature correction	step proportional
9	14	14	14	9	14	14	0 1-2 3 4-5 6 7-9 10-12 13-15 16 17-55 56 57- 95 96 97-134 135 136-174 175 176-214 215 216- 246 247 248-251 252-255	<b>Virtual colour wheel (All pixels)</b> No function White 2700 K White 2700 K (tungsten emulation)* White 3200 K White 3200 K (tungsten emulation)* White 4200 K White 5600 K White 8000 K <b>Blue</b> (Blue=full, Red+Green+White=0) Red=0, Green→up,Blue =full, White=0 <b>Light Blue</b> (Red=0, Green=full, Blue =full, white=0) Red=0, Green=full, Blue→down, White=0 <b>Green</b> (Red=0, Green=full, Blue =0, White=0) Red→up, Green=full, Blue=0, White=0 <b>Yellow</b> (Red=full, Green=full, Blue=0,White=0) Red=full, Green→down, Blue=0, White=0 <b>Red</b> (Red=full, Green=0, Blue=0, White=0) Red=full, Green=0, Blue→up, White=0 <b>Magenta</b> (Red=full, Green=0, Blue=full, White=0) Red→down, Green=0, Blue=full, White=0 <b>Blue</b> (Red=0, Green=0, Blue=full, White=0) Rainbow effect( with fade time) from min.->max. speed Rainbow effect(without fade time)from min.->max.speed	step step step step step step step step step step proportional step proportional step proportional step proportional step proportional step proportional step proportional step proportional proportional
10	15	15	15	10	15	15	0-2 3-4 5-6 : 181-182 183-255	<b>Pixel effects</b> (see table below DMX chart) No function Effect 1 Effect 2 : Effect 90 Reserved	step step : step
11	16	16	16	11	16	16	0-63 64-127 128-191 192-255	<b>Pixel effects speed</b> Speed from min. —>max. without fade time Speed from max. —>min. without fade time (op. direction) Speed from min. —>max. with fade time Speed from max. —>min. with fade time (op. direction)	proportional proportional proportional proportional

Robin CycFX 8

12	17	17	17	12	17	17	0-255	<b>Zoom coarse</b> Zoom from min. to max. beam angle	proportional
-	18	18	18	-	18	18	0-255	<b>Zoom fine</b> Fine zooming from min.—>max.	proportional
13	19	19	19	13	19	19	0-31 32-63 64-95 96-127 128-143 144-159 160-191 192-223 224-255	<b>Shutter/ Strobe (All pixels)</b> Shutter closed Shutter open Strobe-effect from slow to fast Shutter open Opening pulses in sequences slow--> fast Closing pulses in sequences fast --> slow Shutter open Random strobe-effects from slow to fast Shutter open	step step proportional step proportional proportional step proportional step
14	20	20	20	14	20	20	0 - 255	<b>Dimmer coarse (All pixels)</b> Dimmer intensity from 0% to 100%	proportional
-	21	21	21	-	21	21	0 - 255	<b>Dimmer fine (All pixels)</b> Dimmer intensity from min.—>max.	proportional
-	-	22	22	-	22	22	0-255	<b>Red pixel 1</b> Red LED saturation control (0-100%)	proportional
-	-	23	23	-	23	23	0-255	<b>Green pixel 1</b> Green LED saturation control (0-100%)	proportional
-	-	24	24	-	24	24	0-255	<b>Blue pixel 1</b> Blue LED saturation control (0-100%)	proportional
-	-	-	-	-	25	25	0-255	<b>White pixel 1</b> White LED saturation control (0-100%)	proportional
-	-	-	25	15	-	26	0-255	<b>Dimmer 1</b> Dimmer intensity from 0% to 100%	proportional
-	-	25	26	-	26	27	0-255	<b>Red pixel 2</b> Red LED saturation control (0-100%)	proportional
-	-	26	27	-	27	28	0-255	<b>Green pixel 2</b> Green LED saturation control (0-100%)	proportional
-	-	27	28	-	28	29	0-255	<b>Blue pixel 2</b> Blue LED saturation control (0-100%)	proportional
-	-	-	-	-	29	30	0-255	<b>White pixel 2</b> White LED saturation control (0-100%)	proportional
-	-	-	29	16	-	31	0-255	<b>Dimmer 2</b> Dimmer intensity from 0% to 100%	proportional
-	-	28	30	-	30	32	0-255	<b>Red pixel 3</b> Red LED saturation control (0-100%)	proportional
-	-	29	31	-	31	33	0-255	<b>Green pixel 3</b> Green LED saturation control (0-100%)	proportional
-	-	30	32	-	32	34	0-255	<b>Blue pixel 3</b> Blue LED saturation control (0-100%)	proportional

Robin CycFX 8

-	-	-	-	-	33	35	0-255	<b>White pixel 3</b> White LED saturation control (0-100%)	proportional
-	-	-	33	17	-	36	0-255	<b>Dimmer 3</b> Dimmer intensity from 0% to 100%	proportional
-	-	31	34	-	34	37	0-255	<b>Red pixel 4</b> Red LED saturation control (0-100%)	proportional
-	-	32	35	-	35	38	0-255	<b>Green pixel 4</b> Green LED saturation control (0-100%)	proportional
-	-	33	36	-	36	39	0-255	<b>Blue pixel 4</b> Blue LED saturation control (0-100%)	proportional
-	-	-	-	-	37	40	0-255	<b>White pixel 4</b> White LED saturation control (0-100%)	proportional
-	-	-	37	18	-	41	0-255	<b>Dimmer 4</b> Dimmer intensity from 0% to 100%	proportional
-	-	34	38	-	38	42	0-255	<b>Red pixel 5</b> Red LED saturation control (0-100%)	proportional
-	-	35	39	-	39	43	0-255	<b>Green pixel 5</b> Green LED saturation control (0-100%)	proportional
-	-	36	40	-	40	44	0-255	<b>Blue pixel 5</b> Blue LED saturation control (0-100%)	proportional
-	-	-	-	-	41	45	0-255	<b>White pixel 5</b> White LED saturation control (0-100%)	proportional
-	-	-	41	19	-	46	0-255	<b>Dimmer 5</b> Dimmer intensity from 0% to 100%	proportional
-	-	37	42	-	42	47	0-255	<b>Red pixel 6</b> Red LED saturation control (0-100%)	proportional
-	-	38	43	-	43	48	0-255	<b>Green pixel 6</b> Green LED saturation control (0-100%)	proportional
-	-	39	44	-	44	49	0-255	<b>Blue pixel 6</b> Blue LED saturation control (0-100%)	proportional
-	-	-	-	-	45	50	0-255	<b>White pixel 6</b> White LED saturation control (0-100%)	proportional
-	-	-	45	20	-	51	0-255	<b>Dimmer 6</b> Dimmer intensity from 0% to 100%	proportional
-	-	40	46	-	46	52	0-255	<b>Red pixel 7</b> Red LED saturation control (0-100%)	proportional
-	-	41	47	-	47	53	0-255	<b>Green pixel 7</b> Green LED saturation control (0-100%)	proportional
-	-	42	48	-	48	54	0-255	<b>Blue pixel 7</b> Blue LED saturation control (0-100%)	proportional
-	-	-	-	-	49	55	0-255	<b>White pixel 7</b> White LED saturation control (0-100%)	proportional

## Robin CycFX 8

-	-	-	49	21	-	56	0-255	<b>Dimmer 7</b> Dimmer intensity from 0% to 100%	proportional
-	-	43	50	-	50	57	0-255	<b>Red pixel 8</b> Red LED saturation control (0-100%)	proportional
-	-	44	51	-	51	58	0-255	<b>Green pixel 8</b> Green LED saturation control (0-100%)	proportional
-	-	45	52	-	52	59	0-255	<b>Blue pixel 8</b> Blue LED saturation control (0-100%)	proportional
-	-	-	-	-	53	60	0-255	<b>White pixel 8</b> White LED saturation control (0-100%)	proportional
-	-	-	53	22	-	61	0-255	<b>Dimmer 8</b> Dimmer intensity from 0% to 100%	proportional

\*Halogen lamp effect during dimming

Tilt movement direction and pixel order:

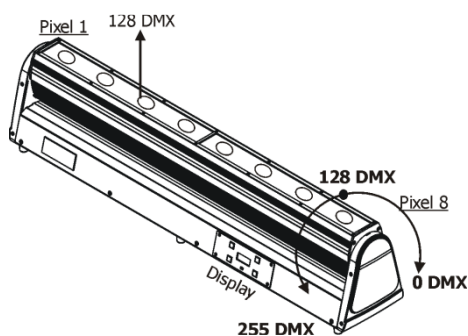

### Channel Pixel effects

DMX value	Effect	Type of Control
0-2	No function	Step
3-4	Effect 1	Step
5-6	Effect 2	Step
7-8	Effect 3	Step
9-10	Effect 4	Step
11-12	Effect 5	Step
13-14	Effect 6	Step
15-16	Effect 7	Step
17-18	Effect 8	Step
19-20	Effect 9	Step
21-22	Effect 10	Step
23-24	Effect 11	Step
25-26	Effect 12	Step
27-28	Effect 13	Step
29-30	Effect 14	Step
31-32	Effect 15	Step
33-34	Effect 16	Step
35-36	Effect 17	Step
37-38	Effect 18	Step
39-40	Effect 19	Step
41-42	Effect 20	Step

Robin CycFX 8

43-44	Effect 21	Step
45-46	Effect 22	Step
47-48	Effect 23	Step
49-50	Effect 24	Step
51-52	Effect 25	Step
53-54	Effect 26	Step
55-56	Effect 27	Step
57-58	Effect 28	Step
59-60	Effect 29	Step
61-62	Effect 30	Step
63-64	Effect 31	Step
65-66	Effect 32	Step
67-68	Effect 33	Step
69-70	Effect 34	Step
71-72	Effect 35	Step
73-74	Effect 36	Step
75-76	Effect 37	Step
77-78	Effect 38	Step
79-80	Effect 39	Step
81-82	Effect 40	Step
83-84	Effect 41	Step
85-86	Effect 42	Step
87-88	Effect 43	Step
89-90	Effect 44	Step
91-92	Effect 45	Step
93-94	Effect 46	Step
95-96	Effect 47	Step
97-98	Effect 48	Step
99-100	Effect 49	Step
101-102	Effect 50	Step
103-104	Effect 51	Step
105-106	Effect 52	Step
107-108	Effect 53	Step
109-110	Effect 54	Step
111-112	Effect 55	Step
113-114	Effect 56	Step
115-116	Effect 57	Step
117-118	Effect 58	Step
119-120	Effect 59	Step
121-122	Effect 60	Step
123-124	Effect 61	Step
125-126	Effect 62	Step
127-128	Effect 63	Step
129-130	Effect 64	Step
131-132	Effect 65	Step
133-134	Effect 66	Step
135-136	Effect 67	Step
137-138	Effect 68	Step
139-140	Effect 69	Step
141-142	Effect 70	Step
143-144	Effect 71	Step
145-146	Effect 72	Step

Robin CycFX 8

147-148	Effect 73	Step
149-150	Effect 74	Step
151-152	Effect 75	Step
153-154	Effect 76	Step
155-156	Effect 77	Step
157-158	Effect 78	Step
159-160	Effect 79	Step
161-162	Effect 80	Step
163-164	Effect 81	Step
165-166	Effect 82	Step
167-168	Effect 83	Step
169-170	Effect 84	Step
171-172	Effect 85	Step
173-174	Effect 86	Step
175-176	Effect 87	Step
177-178	Effect 88	Step
179-180	Effect 89	Step
181-182	Effect 90	Step
183-255	Reserved	

## 5. Control menu map

Default settings=Bold print

Level 1	Level 2	Level 3	Level 4	Level 5	Level 6	Level 7
<b>DMXA</b>	Set DMXA	001-255				
<b>Info</b>	POn Time	Total				
		Reset				
	DMX In	Tilt	0-255			
		:				
		Dimm F	0-255			
	Temp	Current				
		High Res				
		Highest				
	Sw Ver	IC-1				
		IC-2				
		IC-3				
		IC-4				
<b>Pers</b>						
	DMX Pres	<b>Mode 1</b>				
		:				
		Mode 7				
	DMX In	Wired				
		Wireless				
	Tilt Rev	On, <b>Off</b>				
	T. Mode	<b>Speed</b>				
		Time				
	T. Feed	On, Off				
	BLC DMC	On, <b>Off</b>				
	Act BLC	T Mov	On, <b>Off</b>			
	Display	Turn				

Robin CycFX 8

Level 1	Level 2	Level 3	Level 4	Level 5	Level 6	Level 7
		On/Off T	On, Off			
		Contrast	0-100%			
		Backlight	0-100%			
	C Cal M	<b>On, Off</b>				
	C Mix M	<b>RGBW, CMY</b>				
	Whi Cnt	<b>On, Off</b>				
	Sil Zom	<b>On, Off</b>				
	Mic Sens	0... <b>10</b> ...19				
	I Ef Pos	Tilt				
		:				
		Dimm F				
		Store				
	Defaults					
<b>Manual</b>	Tilt					
	:					
	Dimm F					
<b>Test Prg</b>						
<b>Sta Alone</b>	Music T	<b>On, Off</b>				
	Auto Run	<b>Off</b>				
		Test				
		User				
	Pr Play	Test Prg				
		User Prg				
	Pr Edit	Step 1	Prg End			
		:	Tilt			
		Step 42	:			
			Copy			

Robin CycFX 8

Level 1	Level 2	Level 3	Level 4	Level 5	Level 6	Level 7
Reset						
Special	RDM Low					
	RDM Hight					
	Wireless	Stat				
		Unlink				
	Adjust	DMX Val	Tilt	0-255		
			:			
			Dimm F	0-255		
		Calib	Cal Mech	Tilt C.	0-255	
				Store		
			Cal Col	R C 1	0-255	
				G C 1	0-255	
				B C 1	0-255	
				W C 1	0-255	
				:		
				R C 8	0-255	
				G C 8	0-255	
				B C 8	0-255	
				W C 8	0-255	
				Store		
			Cal Temp			
		Load d C				
	Sw Upd	On, Off				

## 6. Control menu

The Robin CycFX 8 is equipped with 2-line LCD display which allows to set the fixture's behaviour according to your needs, obtain information on its operation, control various range of effects and lastly program it, if it has to be used in a stand-alone mode.

Control board:

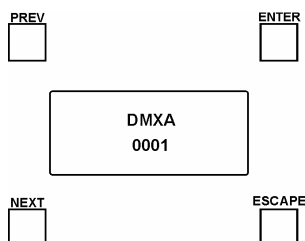

[ESCAPE] button used to leave the menu without saving changes.

[NEXT] , [PREV] buttons for moving between menu items and for value adjusting.

[ENTER] button used to enter the selected menu (menu item) and to confirm adjusted value.

After switching the fixture on, display shows current DMX address.

**Note:** to turn the display , press and hold the [ESCAPE].

### 6.1 Addressing (DMXA)

**Set DMXA-** Use this menu item to set the DMX start address of the fixture, which is defined as the first channel from which the Robin will respond to the controller.

If you set, for example, the address 15, the Robin CycFX 8 will use channels 15 - 28 for control (if Mode 1 is selected).

Please, be sure that you do not have any overlapping channels in order to control each Robin CycFX 8 correctly and independently from any other fixture on the DMX data link.

If there is no data received at the DMX input, the display will start to flash "0001" with actually stored DMX address.

### 6.2 Fixture information (Info)

**POn Time - Power on time.** Select this menu to read the number of fixture operation hours.

**Total** - The item shows the total number of the operation hours since the Robin CycFX 8 has been fabricated.

**Reset** - The item shows the number of the operation hours that the Robin CycFX 8 has been powered on since the counter was last reset.

In order to reset this counter to 0, press and hold both [NEXT] and [PREV] buttons and the [Enter] button at the same time.

**DMX In - DMX readout.** The menu is used to read DMX values of each channel received by the fixture.

**Temp - Temperature.** The menu shows temperature in the moving LED head.

**Current** - A current temperature of the moving LED head.

**Highest** - A maximum temperature of the moving LED head since the fixture has been fabricated.

**High Res** - A maximum temperature of the the moving LED head since the counter was last reset.

In order to reset this counter, press and hold both [NEXT] and [PREV] buttons and the [Enter] button at the same time.

**Sw Ver - Software versions.** Select this item to read the software version of the fixture modules.

**IC-1** - A zoom processor.

**IC-2** - A display processor.

**IC-3** - LED driver processor.

**IC-4** - LED control processor

### 6.3 Personality (Pers)

**DMX Pres - DMX preset.** Use the menu to select desired channel mode.

**Mode 1** - 14 control channels

**Mode 2** - 21 control channels

**Mode 3** - 45 control channels

**Mode 4** - 53 control channels

**Mode 5** - 22 control channels

**Mode 6** - 53 control channels

**Mode 7** - 61 control channels

**DMX In - DMX input.** Use the menu to select mode of receiving DMX signal.

**Wired** - DMX signal is received by means of the standard DMX cable.

**Wireless** - DMX signal is received by means of the inbuilt wireless module.

**Tilt Rev - Tilt reverse.** The item allows to invert tilt movement of the LED head.

**T Feed - Tilt Feedback.** The menu item allows to return the mowing head to the required tilt position after changing the position by an external force if this option is set on.

Note. The Tilt Feedback should be permanent On, the option Off is not suitable for standard operation and the head of the fixture can be damaged!

**BLC DMC - Blackout during movement correction.** Set this option on if you wish to close light output during the time when the head goes to its correct position, which has been changed by an external force.

**Act Blc - Active blackout.** Use this menu if you wish to close the light output during effect changes.

**P/T Mov** - The menu item allows to close light output while the tilt coordinates are changing.

**Display - Display adjusting.** This menu allows you to adjust the display behaviour.

**Turn** - This function turns the display by 180°.

**On/Off T** - This function allows you to keep the display permanent on or turn it off two minutes after last pressing any button on the control panel.

**Contrast** - Use this function to adjust contrast of the display (0-100%).

**Backlight** - Use this function to adjust backlight of the display (0-100%).

**C Cal M - Colour calibration mode.** If the function is on, the white output (2700K-8000K) from the fixture (and also mixed colours) is more uniform. Each colour is dynamically corrected according to the value set in the menu "Calibrate Effects" (Special-> Adjust-> Calib).

**C Mix M - Colour mixing mode.** This item allows switching into RGBW or CMY mode. In the CMY mode, the white(8bit)/white (16) bit channels are not active.

**Whi Cnt - White counting.** If this function is On, the white LED of each pixel lights when a white colour is mixed. The light intensity of the white LED is in a proportion to the intensity of the rest of pixel's LEDs (red, Green, blue)



Power	a power/special functions	R L 1	a red LED pixel 1
R L A	red LEDs (all pixels)	G L 1	a green LED pixel 1
G L A	green LEDs (all pixels)	B L 1	a blue LED pixel 1
B L A	blue LEDs (all pixels)	Dim 1	a dimmer for pixel 1
W L A	white LEDs (all pixels)	R L 8	a red LED pixel 8
CTO	a colour temperature correction	G L 8	a green LED pixel 8
Vir C	a virtual colour	B L 8	a blue LED pixel 8
Pix E	pixel effects	Dim 1	a dimmer for pixel 1
Px E S	a pixel effect speed	S.Tm	a step time (0-25.5 sec)
Zoom	a zoom movement	COPY	copying the current prog. step to the next prog. step

4. Press [ENTER] button to confirm adjusted value .

5. Press [ESCAPE] button, select next prog. step, press [ENTER] button and repeat steps 3 - 5).

## 6.7 Reset

This option enables the Robin CycFX 8 to index all effects and return to their standard positions.

## 6.8 Special functions (Special)

**RDM Low** - This menu item shows the first part of the RDM identification code.

**RDM High** - This menu item shows the second part of the RDM identification code.

**Wireless** - **Wireless DMX status**. The menu serves for reading of the wireless operation status.

**Stat** - **Wireless DMX information**. The menu item shows level of received signal in %.

**UnLink** - **Wireless DMX unlink**. The item serves for unlinking the fixture from transmitter.

**Adjust** - **Adjustment**. The menu allows the fine adjustment of colours.

**DMX Val**- **DMX values**. Use the menu to set DMX values of fixture's channels.

**Calib** - A calibration of tilt position of head and white colours.

**Cal Mech** - A calibration of tilt position.

Note: you can also use DMX controller for calibration of tilt position of head, calibration protocol is following:

<b>Effect</b>	<b>Mode 1</b>	<b>Mode 2</b>	<b>Mode 3</b>	<b>Mode 4</b>
Tilt- fine tilt movement	channel 15	channel 22	channel 46	channel 54

**Cal Col** - A calibration of colours.

**Cal Temp** - A setting of temperature of the control processor for LEDs calibration. This temperature has to be set before calibration of colours. Disconnect the fixture from mains and let it at room temperature (cca 25°C) until the fixture gets ambient temperature (as it can last 2 hours and more, better is used cold fixture before its operation). After that, set the ambient (room) temperature in this menu.

**Sw Upd** - **Software update**. The menu item allows you to update software in the fixture via either serial or USB port of PC.

The following are required in order to update software:

- PC running Windows 95/98/2000/XP/7 or Linux
- DMX Software Uploader
- Flash cable RS232/DMX No.13050624 (if you want to use a serial port of PC)
- Robe Universal Interface (if you want to use an USB port of PC)

Note 1: Software update should execute a qualified person. If you lack qualification, do not attempt the update yourself and ask for help your ROBE distributor.

Note 2: DMX address, programs 1-3 and all items in the menu "Pers" will be set to their default (factory) values.

*To update software in the fixture:*

I. Installation of the DMX Software Uploader.

1. DMX Software Uploader program is available from the ROBE web site at WWW.robe.cz.
2. Make a new directory ( e.g. Robe\_Uploader) on your hard disk and download the software to it.
3. Unpack the program to the directory.

II. Fixture software updating.

1. Determine which of your ports is available on your PC and connect it:

- with the DMX input of the fixture if you using the flash cable RS232/DMX
- with the DMX output of the Robe Universal Interface if you using the USB cable.

Disconnect the fixture from the other fixtures in a DMX chain. Turn both the computer and the fixture on. Make sure the lamp is switched off (only if the fixture involves a lamp).

2. Switch the fixture to the updating mode by selecting the "SW Upd " item and press [ENTER].

Note: If you do not want to continue in software update, you have to switch off and on the fixture to escape from this menu.

We recommend to cancel all running programs before starting the Software Uploader.

3. Run the Software Uploader program. Select desired COM and then click on the Connect button. (Select COM if the serial port is used or Robe Universal Interface if the USB port is used).

If the connection is OK, click on the "Start Uploading button" to start uploading. It will take several minutes to perform software update.

If the option "Incremental Update" is not checked, all processors will be updated (including processors with the same software version).

If you wish to update only later versions of processors, check the "Incremental Update box".

Avoid interrupting the process. Update status is being displayed in the Info Box window.

When the update is finished, the line with the text "The fixture is successfully updated" will appear in this window and the fixture will reset with the new software.

Note: In the case of an interruption of the upload process (e.g. power cut), the fixture keeps the updating mode and you have to repeat the software update again.

## 7. RDM

This fixture is ready for RDM operation. RDM (Remote Device Management) is a bi-directional communications protocol for use in DMX512 control systems, it is the new open standard for DMX512 device configuration and status monitoring.

The RDM protocol allows data packets to be inserted into a DMX512 data stream without adversely affecting existing non-RDM equipment. By using a special „Start Code,“ and by complying with the timing specifications for DMX512, the RDM protocol allows a console or dedicated RDM controller to send commands to and receive messages from specific moving lights.

RDM allows explicit commands to be sent to a device and responses to be received from it.

The list of commands for Robin 8 is the following.

Parameter ID	Discovery command	SET command	GET command
DISC_UNIQUE_BRANCH	*		
DISC_MUTE	*		
DISC_UN_MUTE	*		
DEVICE_INFO			*
SUPPORTED_PARAMETERS			*
SOFTWARE_VERSION_LABEL			*
DMX_START_ADDRESS		*	*

IDENTIFY_DEVICE		*	*
DEVICE_MODEL_DESCRIPTION			*
MANUFACTURER_LABEL			*
DEVICE_LABEL		*	*
SENSOR_DEFINITION			*
SENSOR_VALUE			*
DISPLAY_LEVEL		*	*
DEVICE_RESET		*	
DMX_PERSONALITY		*	*
DMX_PERSONALITY_DESCRIPTION			*
STATUS_MESSAGES			*
STATUS_ID_DESCRIPTION			*
DEVICE_HOURS			*

Please, see the Robe Universal Interface user manual for detail description of RDM operation.

## 8. Technical specifications

### Power supply

- Electronic auto-ranging
- Input voltage: 100 - 240V AC, 50-60 Hz
- Fuse: T 5A
- Max. power consumption\*: 150W@230V (power factor=0,94; I=0,64A)

\*Allow for a deviation of +/-10%

- Mains input: CE - max. 16A  
cETLus - max. 10 A
- Mains output: CE - max. 15A  
cETLus - max. 9 A

### Optic & Effects

- Light source: Array of 8 x 15W RGBW LED multichips
- Zoom range: x-axis: 12°-43°( at ½ beamu)  
20°-67° (at 1/10 beamu )  
y-axis: 8°-40°( at ½ beamu)  
15°-62°(at 1/10 beamu )
- RGBW or CMY colour mixing
- Built-in colour macros and pixel effects
- Adjustable strobe sequences
- Typical Lumen maintenance: 70% @ 60.000 hours

### Control

- Setting & Addressing: two-row LCD display & 4 control buttons
- Control: USITT DMX 512 (RDM support)
- DMX protocol modes: 7 (14,21,45,53,22,53,61 control channels)

## Robin CycFX 8

- Operations modes: DMX, Stand-alone
- Manual control of all effects via control panel
- One editable program, up to 42 steps

### **Wireless DMX/RDM module (only for Robin CycFX 8 Wireless DMX)**

- Compliance with USITT DMX-512 (1986 & 1990) and 512-A
- Full DMX fidelity and frame integrity
- Auto sensing of DMX frame rate and frame size
- <5ms DMX latency
- Operational frequency range of 2402-2480 MHz
- Producer: LumenRadio

### **Strobe**

- Strobe effect with variable speed (max. 20 flashes per second)
- Pre-programmed random strobe pulse-effects

### **Dimmer**

- Smooth 16-bit dimming from 0 - 100 %

### **Connection**

- DMX data in/out: Locking 3-pin & 5-pin XLR
- Power In: Chassis connector Neutrik PowerCon, A-type, NAC3MPA
- Power Out: Chassis connector Neutrik PowerCon, B-type, NAC3MPB

### **Rigging**

- Via 2 mounting adapters

### **Temperatures**

- Maximum ambient temperature: 40° C
- Maximum housing temperature: 70° C

### **Minimum distances**

Min. distance from flammable surfaces: 0.2 m

Min. distance to lighted object: 0.3 m

### **Total heat dissipation**

- 648 BTU/h (calculated)

### **Weight**

- 12 kg

## Robin CycFX 8

### Dimensions (mm)

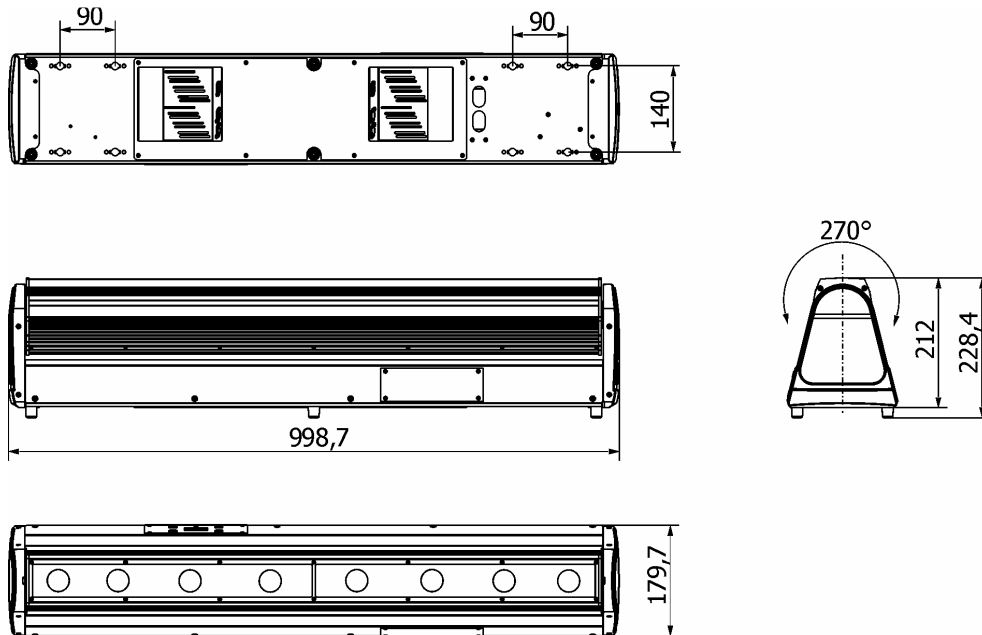

### Mounting bar CF8 (optional)

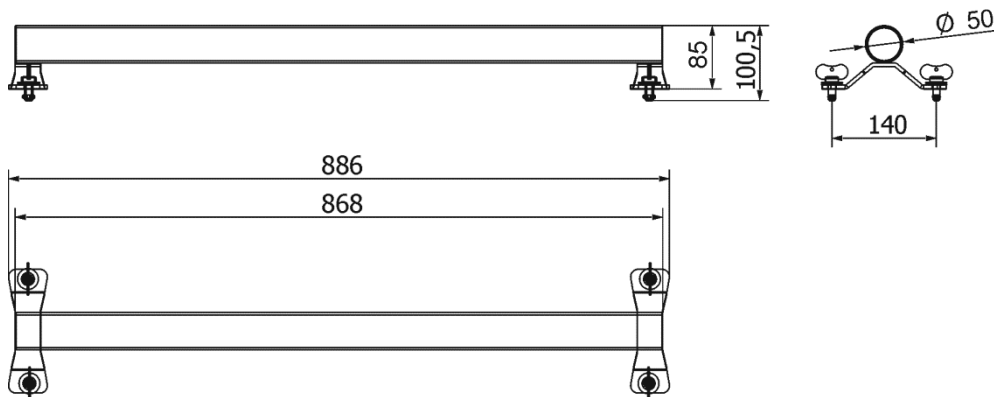

### Included items

- 1 x Robin CycFX
- 1 x Omega clamps CL CycFx 8 2pcs in box (P/N 10980223)
- 1x Power cable (one type only):
  - (P/N1305 1731) Mains Cable PowerCon In/open ended, 2m
  - (P/N 1305 1724) Mains Cable PowerCon In/Schuko, 2m
  - (P/N 1305 1725) Mains Cable PowerCon In/CEE 16A, 2m
  - (P/N 1305 1726) Mains Cable PowerCon In/US, 2m
- 1 x User manual

### Optional accessories

- (P/N10980184) Omega clamps TCL regular CycFx4 2pcs in box
- (P/N 1305 1727) Daisy Chain PowerCon In/Out, EU, 2m
- (P/N 1305 1728 ) Daisy Chain PowerCon In/Out, US, 2m
- (P/N 10980190) Mounting bar CF8
- (P/N 9903 0151) Upgrade kit CRMX for CycFx 4/8

# Robin CycFX 8

## Beam distribution

### Min. zoom

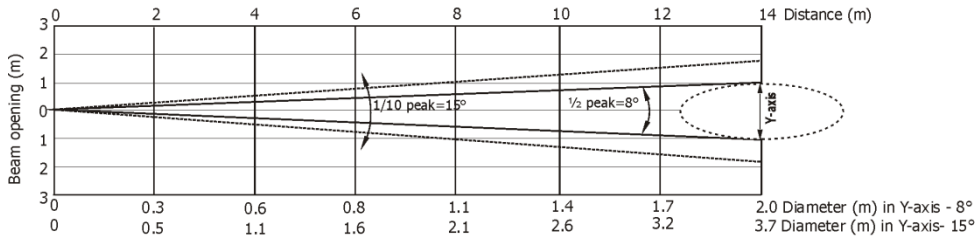
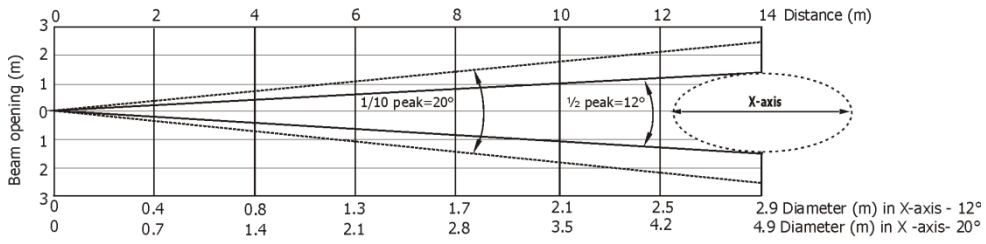

Distance (m)	2	4	5	6	8	10	12	14	
Red	2653/238	641/60	410/38	285/27	160/15	103/10	71/7	52/5	Intensity (center) Lux/Footcandles
Green	5500/511	1375/128	880/82	611/57	344/32	220/20	153/14	112/10	
Blue	706/66	177/16	113/10.5	79/7	44/4	26/2.4	20/1.8	14/1.3	
White	6944/645	1736/161	1111/103	772/72	434/40	278/26	193/18	142/103	
R+G+B+W	14344/1333	3586/333	2295/213	1594/148	897/83	574/53	398/37	293/27	

### Illuminance distribution in X-axis

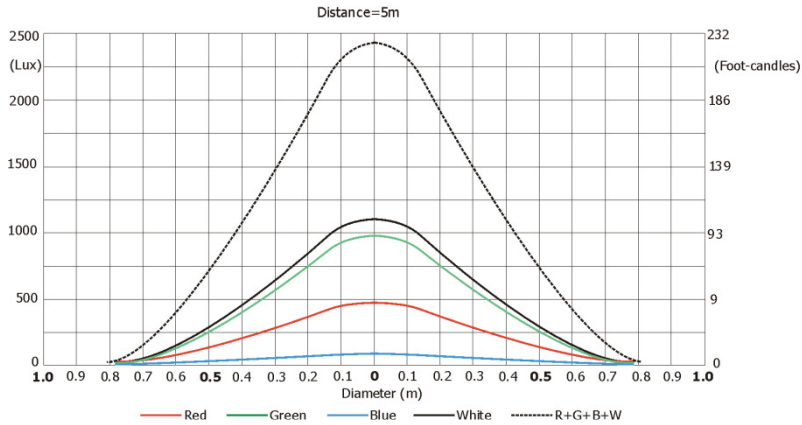

### Illuminance distribution in Y-axis

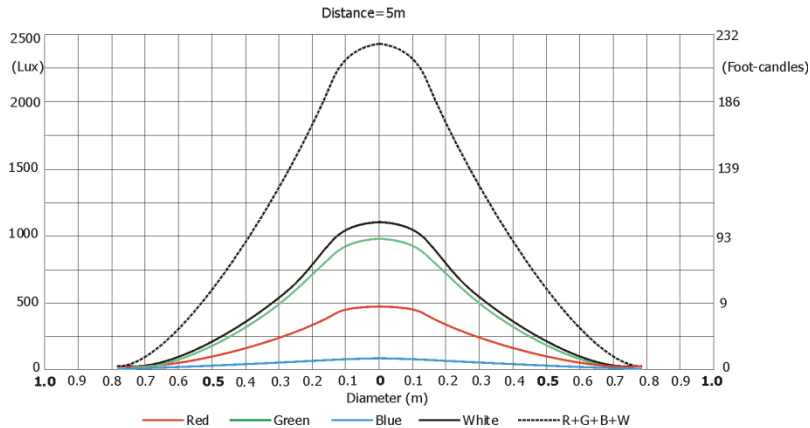

# Robin CycFX 8

## Max. zoom

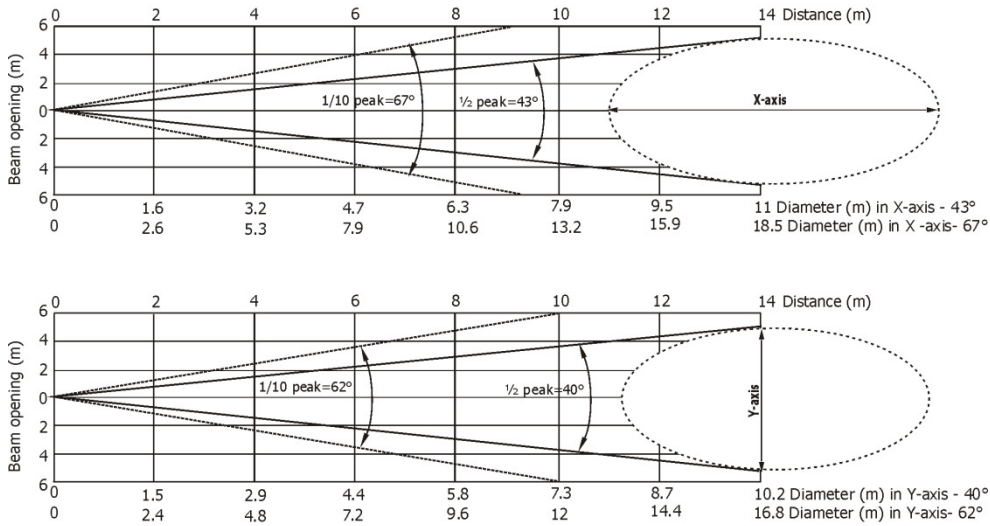

Distance (m)	2	4	5	6	8	10	12	14	
Red	138/13	34/3	22/2	15/1.4	9/0.8	6/0.5	4/0.4	3/0.3	Intensity (center) Lux/footcandles
Green	331/31	83/8	53/5	37/3	21/2	13/1.2	9/0.9	7/0.6	
Blue	50/5	13/1.2	8/0.7	6/0.5	3/0.3	2/0.2	1.4/0.1	1/0.1	
White	394/37	98/9	63/6	44/4	25/2.3	16/1.5	11/1	8/0.7	
R+G+B+W	825/76	206/19	132/12	92/9	52/5	33/3	23/2	17/1.6	

## Illuminance distribution in X-axis

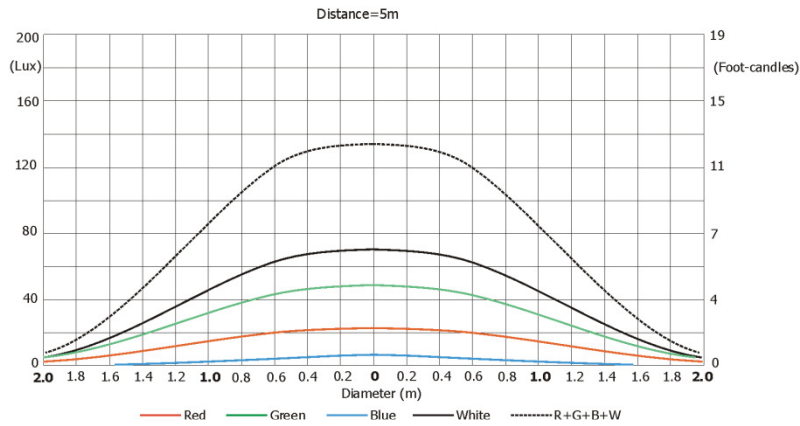

## Illuminance distribution in Y-axis

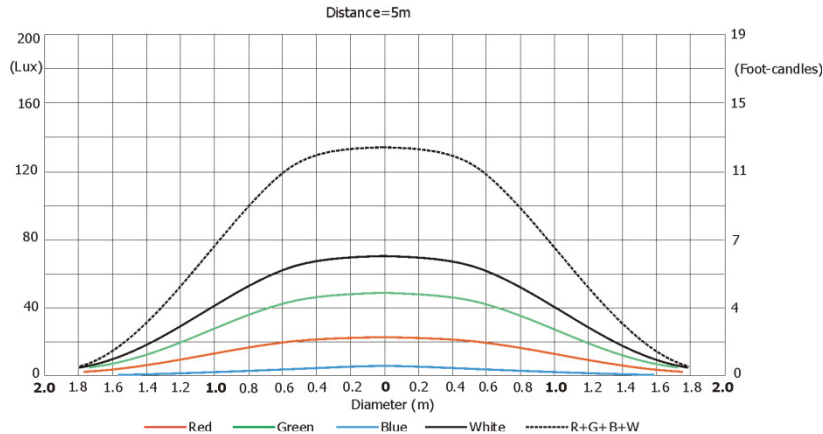

## 9. Cleaning and maintenance

**DANGER !**  
***Disconnect from the mains before starting any cleaning or maintenance work***

The front transparent cover will require monthly cleaning as smoke fluid tends to build up residues, reducing the light output very quickly. For cleaning use a wet cloth or an air-jet. Do not use solvents or any other aggressive cleaning fluid.

Maintenance and service operations are only to be carried out by a qualified person.  
Should you need any spare parts, please use genuine parts.

### 9.1 Replacing a fuse

This replacement has to be realized by a qualified person or ROBE service worker only.

*Specifications are subject to change without notice*

*August 31, 2016*